

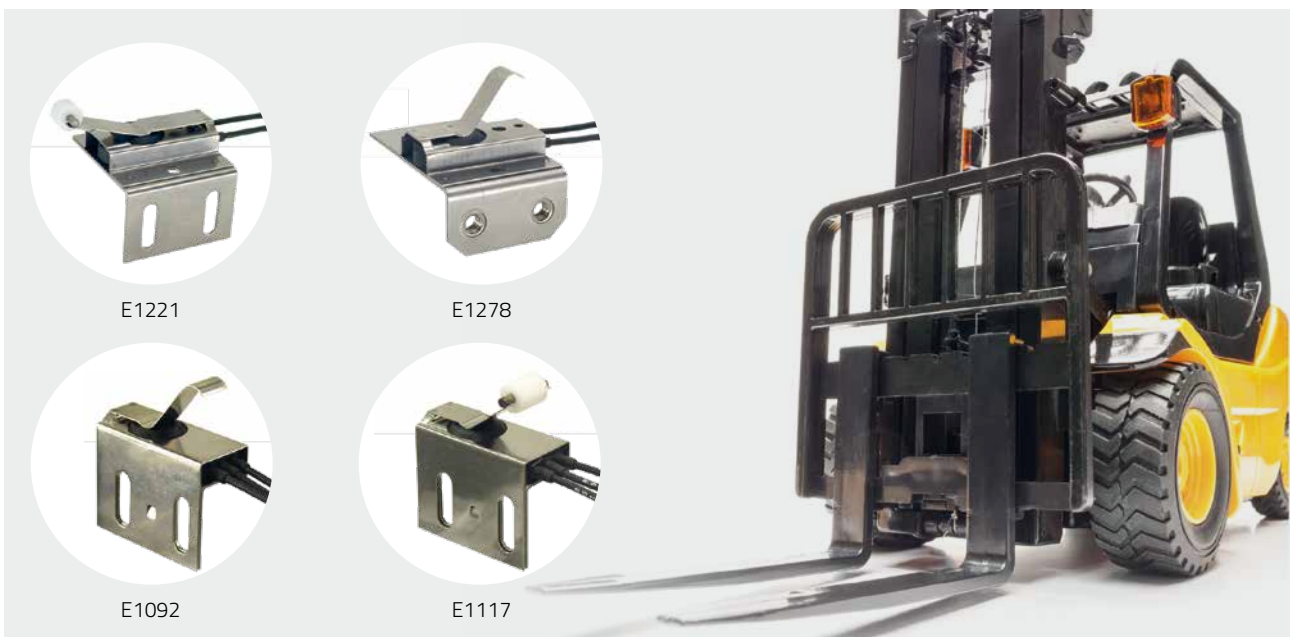

Control Products Inc.

Waterproof Limit Switches for Lift Truck Applications

CPI manufactures high-endurance waterproof and thermal switches plus indestructible hydraulic position sensors for one purpose – to bring precision, efficiency, reliability and safety to your equipment, in the most demanding applications.



Truly Waterproof Limit Switches

CPI's limit switches have a proven track record on commercial lift truck equipment, for OEM and aftermarket applications. Reliable operation under exposure to wet conditions, dust, vibration, and shock.

- All stainless steel actuators & brackets
- Sealed to IP68
- UL Listed
- Sealed connectors/terminals available

Specifications

Electrical rating: E1s:

(28VDC / 120VAC): 5 amps resistive, 3 amps inductive. Higher ratings available on special order. UL recognized for 120VAC, 5 amp resistive rating upon request.

Endurance:

100,000 to 5 million cycles (depending on configuration)

Operating temperature range:

-45°C to 105°C

Environmental resistance:

Excellent resistance to both high and low temperatures, acids, alkalis, salt spray, sand, dust, fungus, and cleaning chemicals.

Applications

- Brake inching switch
- Battery compartment door / tray position
- Mast limit detection
- Operator presence detection
- Auxiliary control for attachments can be mounted on joystick (momentary B Series shown)



General Product Dimensions

E1092 angle mount limit bracket with simulated roller actuator
 (shown as example - please visit www.cpi-nj.com for other mounting/actuator configurations)

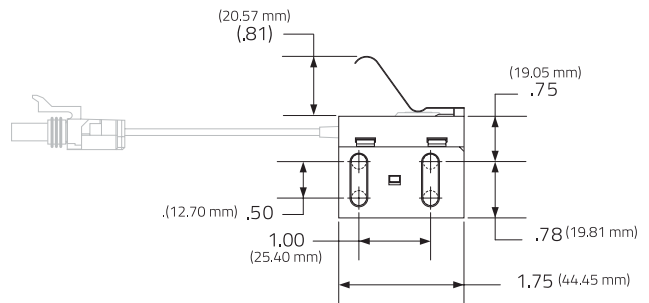
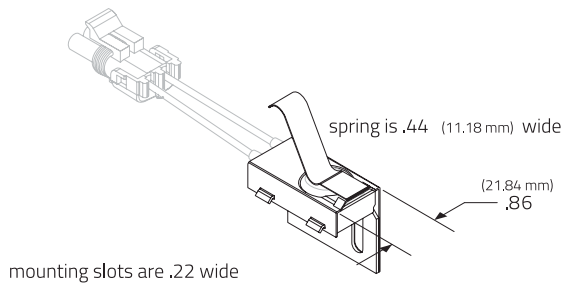

E1112 = opposite angle

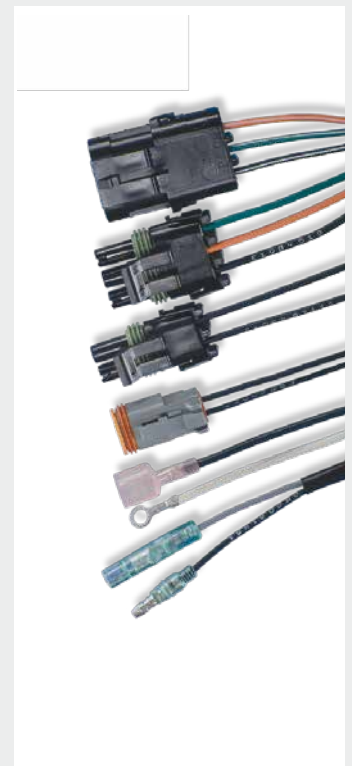

Wire Terminations, Connectors and Wire Coverings

Along with CPI's offering of standard wire and cable leads, we also have available special terminations to meet your specifications. Variations include special color-coded wire, BUNA-N, coil cords, and alternative wire gauges. Connectors, wire markers, and sleeving may also be specified, creating a complete switch/harness assembly.

The main advantage is that you will receive a complete assembly from CPI rather than a third-party harness house. In addition, you will receive the highest quality possible, as CPI is your most qualified source when it comes to integrating terminations with our sealed switches.



Netherlands
 Head office

Van Dalenlaan 398
 2082 VR Santpoort-Zuid

T +31-(0)23-5384644
 ask@ippbv.com

Please check www.ippbv.com for further
 information or contact details.